

# FNC series

GANG TYPE CNC LATHE



FORCE ONE MACHINERY CO.,LTD.

No.5,Ln. 272,Dalin Rd.,Daya Dist. Taichung City 428,Taiwan

Tel: +886-4-2560 2500 Fax: +886-4-2560 2400

E-mail: sales@forceonecnc.com <http://www.forceonecnc.com>

First edition third print 07 . Aug . 2024

# FNC series

GANG TYPE CNC LATHE

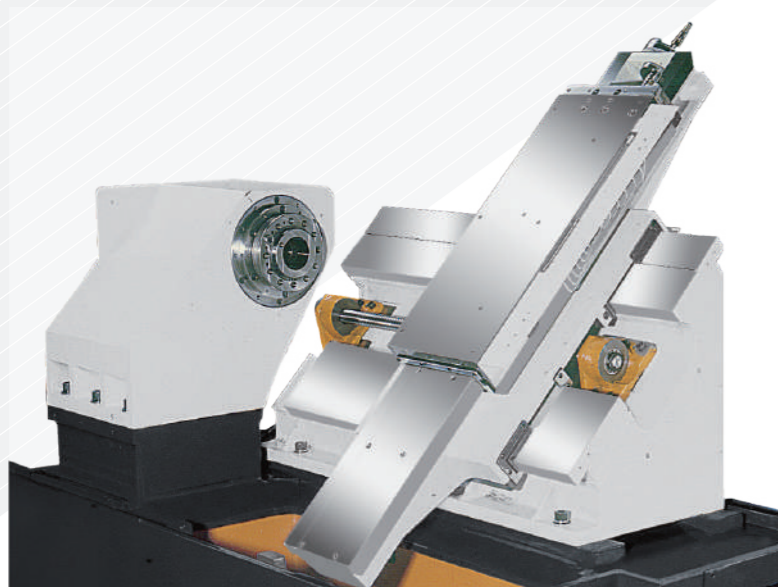

The bed is one piece 45° slant cast iron design. Widely spaced hardened and ground slideways combined with the 32 mm dia. Z axis ball screw give exceptional rigidity. The slideways are coated with teflon to eliminate stick slip, minimize wear and maintain long term accuracy.

## WORKING RANGE

FNC-10 / 10A / 15

A : 10 (FNC-10 / 10A)

A : 60 (FNC-15)

CHUCK SIZE :

FNC-10 : 6"

FNC-10A : 8"

FNC-15 : 10"

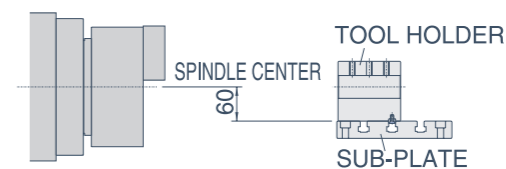
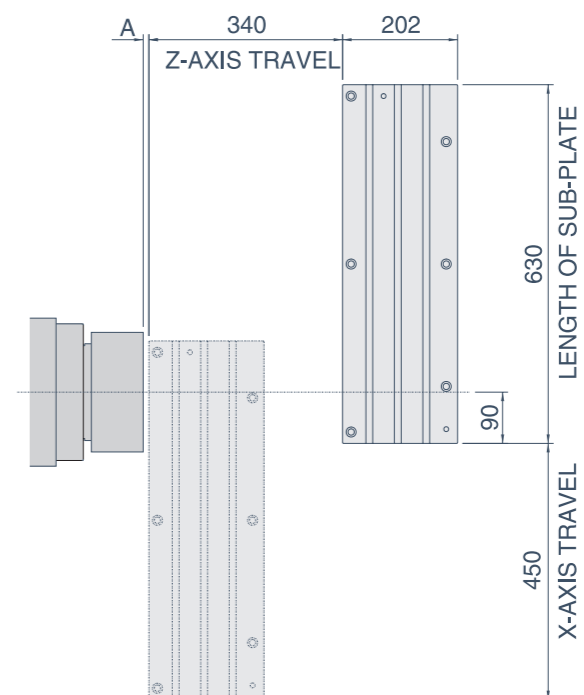

## TOOLING SYSTEM

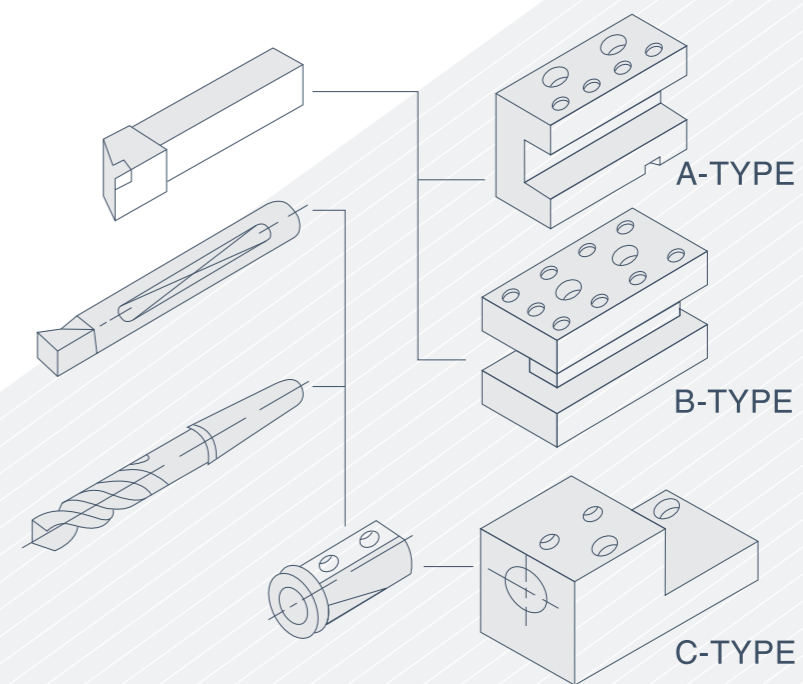



# SPECIFICATIONS

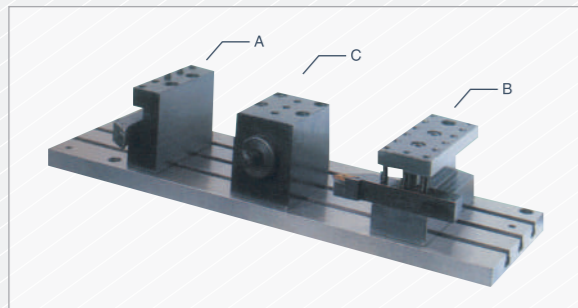

## ADDITIONAL SUB-PLATE FOR CUTTING TOOLS PRESET

The tool utilizes dual-axis rapid linear movement, resulting in a faster tool change time compared to the tool turret's tool holder. The auxiliary tool holder can also be used for tool presetting, further reducing tool change and setup times.



## HEADSTOCK

The headstock design allows efficient heat dissipation for maximum thermal stability.

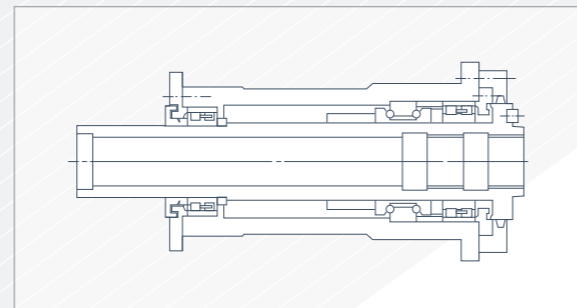

## RIGID HIGH SPEED SPINDLE

The main spindle is supported by five precision angular contact bearings combining high accuracy with rigidity for heavy metal removal.



## OPERATOR CONVENIENCE BY FANUC

The built-in control console is always accessible to the operator and contains all manual, semi-automatic, and CNC function controls.

MODEL	ITEM	FNC-10	FNC-10A	FNC-15
Capacity	Swing over bed / Sub plate	Dia. 400 / 120 mm (15.7" / 4.7")	Dia. 400 / 120 mm (15.7" / 4.7")	Dia. 410 / 120 mm (15.7" / 4.7")
	Sub plate length	630 mm (24.8")	630 mm (24.8")	630 mm (24.8")
	Hydraulic chuck	Dia. 160 mm	Dia. 210 mm	Dia. 254 mm
Spindle	Spindle nose	A2-5	A2-6	A2-8
	Spindle bearing diameter	Dia. 90 mm (3.5")	Dia. 100 mm (3.9")	Dia. 130 mm (5.1")
	Spindle bore	Dia. 56 mm (2.2")	Dia. 62 mm (2.4")	Dia. 87 mm (3.4")
	Bar capacity	Dia. 45 mm (1.7")	Dia. 52 mm (2")	Dia. 75 mm (2.9")
	Spindle taper	MT6	1:20	1:20
	Spindle speed	40 ~ 4000 rpm	40 ~ 4000 rpm	40 ~ 3200 rpm
Slides	Longitudinal carriage travel (Z)	340 mm (13.3")	340 mm (13.3")	340 mm (13.3")
	Cross slide travel (X)	450 mm (17.7")	450 mm (17.7")	450 mm (17.7")
	X axis rapid traverse	15 m/min	15 m/min	15 m/min
	Z axis rapid traverse	15 m/min	15 m/min	15 m/min
Tool holder	ID Tool holder dia	Dia. 40 mm (1.6")	Dia. 40 mm (1.6")	Dia. 40 mm (1.6")
	OD Tool holder size	20 x 20 mm	25 x 25 mm	25 x 25 mm
Bed	Width	560 mm (22")	560 mm (22")	560 mm (22")
	Slant angle	45°	45°	45°
Motor	Spindle	$\beta$ iIP 18.9/11 kW	$\beta$ iIP 18.9/11 kW	$\alpha$ iIP 22.11/15 kW
	X axis servo motor	1.8 kW	1.8 kW	1.6 kW
	Z axis servo motor	1.8 kW	1.8 kW	3.0 kW
	Hydraulic motor	0.75 kW	0.75 kW	0.75 kW
	Coolant pump	0.375 kW	0.375 kW	0.375 kW
	Lubrication pump	25 W	25 W	25 W
	Power requirement	22 KVA	22 KVA	22 KVA
	Miscellaneous	X axis ball screw dia	Dia. 32 mm (1.3")	
Z axis ball screw dia	Dia. 32 mm (1.3")			
Miscellaneous	Packing size	2920 x 1810 x 2100 mm (114.9" x 71.2" x 82.6")	2920 x 1810 x 2100 mm (114.9" x 71.2" x 82.6")	3230 x 1810 x 2100 mm (114.9" x 71.2" x 82.6")
	Gross weight	3500 kgs	3500 kgs	3800 kgs

- All specification, design and characteristics shown on this catalogue are subject to change without prior notice.

## FLOOR SPACE

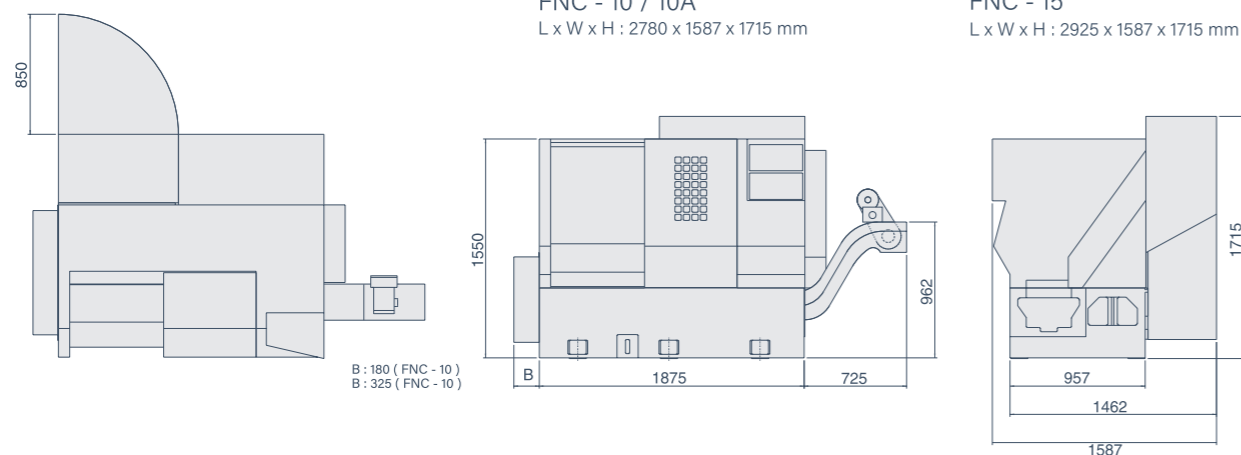

## OUTPUT TORQUE

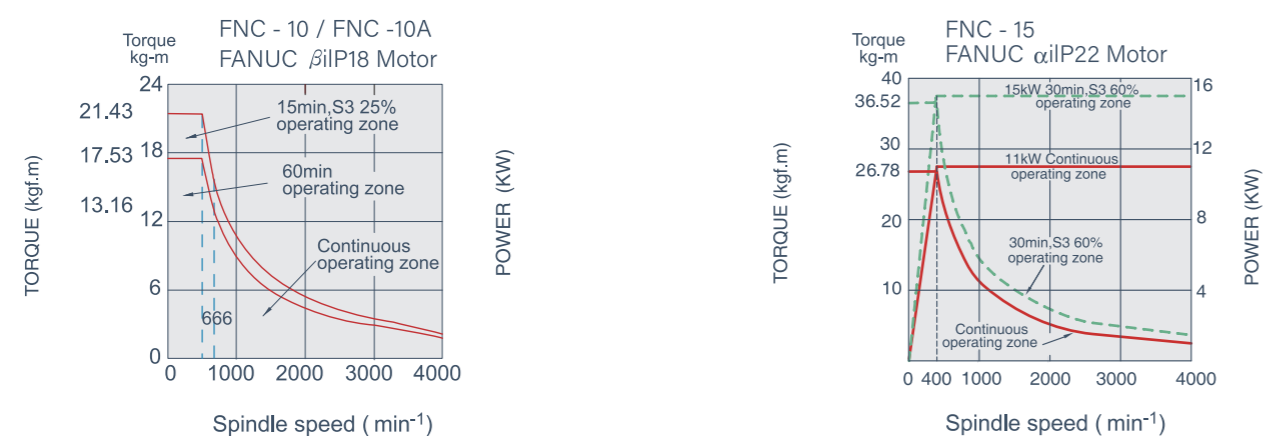

## STANDARD ACCESSORIES

- Hydraulic hollow chuck with cylinder
- Tool holder type A, B, C, (one of each)
- Center sleeve, Dia. 8, 10, 12, 16, 20, 25, 32, MT-2 and MT 3 (one of each)
- Subplate
- Coolant system
- Automatic lubrication system
- Work light
- Chip conveyor

## OPTIONAL ACCESSORIES

- Spindle Orientation Indexing (15)
- Chuck air cleaner
- Bar feeder
- Parts catcher
- Bar puller
- Auto door
- Additional type A, B and C tool holders and sleeves
- Additional Sub-plate
- Milling attachment
- V8 turret
- Collet chuck and collets