

HAN/HAHseries

4 BED WAYS HEAVY DUTY CNC LATHE



FORCE ONE MACHINERY CO.,LTD.

No.5,Ln. 272,Dalin Rd.,Daya Dist. Taichung City 428,Taiwan

Tel: +886-4-2560 2500 Fax: +886-4-2560 2400

E-mail: sales@forceonecnc.com <http://www.forceonecnc.com>

First edition third print 07 . Aug . 2024

HAN/HAH series

4 BED WAYS HEAVY DUTY CNC LATHE

Heavy Turning & High Precision CNC Lathe.
Provide a variety of customized options and configurations.

HAN

Spindle gear ratio: 166:1

Max. Loading (Spindle only): 3000 kg

HAN Series with 9° spindle bore

Max, speed ratio

(Spindle motor: Spindle) 166:1

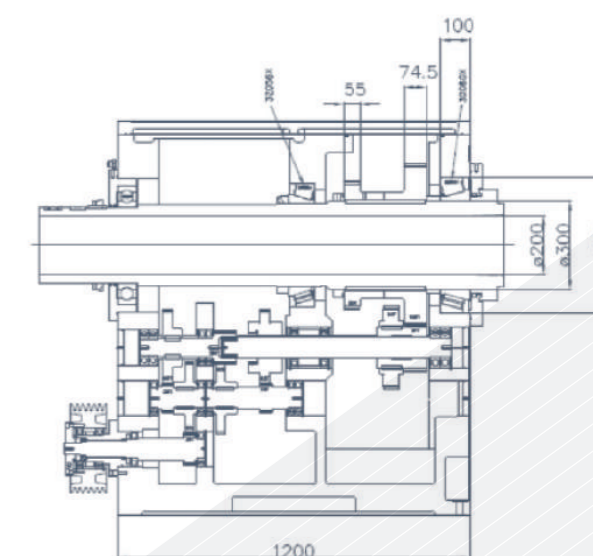
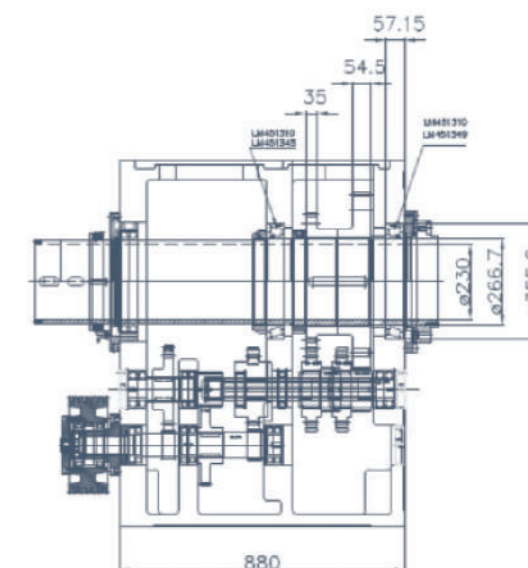

HAH

Spindle gear ratio: 278:1

Max. Loading (Spindle only): 5000 kg

HAH Series with 8° spindle bore

Max, speed ratio

(spindle motor: spindle) 278:1

HAH has longer headstock and spindle, wider and bigger support bearing and transfer gears, also has bigger gear ratio, so HAH has higher rigidity and torque than HAN.

HAH is special design for heavy duty cutting.





Driving tool with Y axis + spindle with CS / CF (option) is available.

Quick change system for turning / boring bar / milling head / grinding attachment.

WORKING RANGE

FULL LENGTH CROSS SLIDE

HALF LENGTH CROSS SLIDE

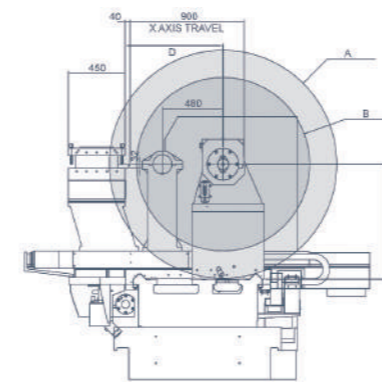

MODEL	A	B	C	D
HA45N/H	1170	720	585	685
HA50N/H	1300	850	650	685
HA55N/H	1430	980	715	685
HA60N/H	1560	1110	780	775
HA70N/H	1800	1370	910	775
HA80N/H	2050	1630	1040	865

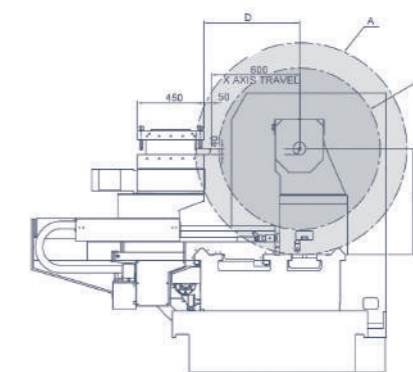

MODEL	A	B	C	D
HA45N/H	1170	845	585	539
HA50N/H	1300	965	650	592
HA55N/H	1430	1090	715	645
HA60N/H	1560	1215	780	698
HA70N/H	1800	1465	910	604
HA80N/H	2050	1715	1040	910

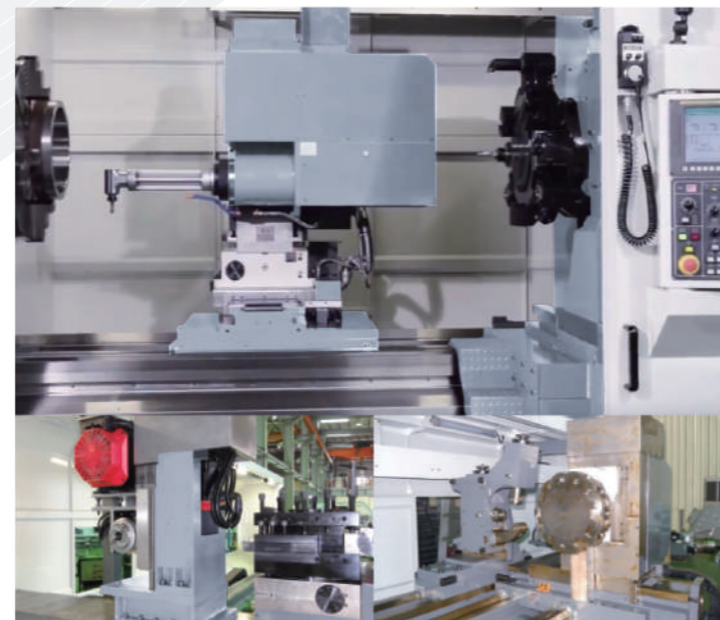
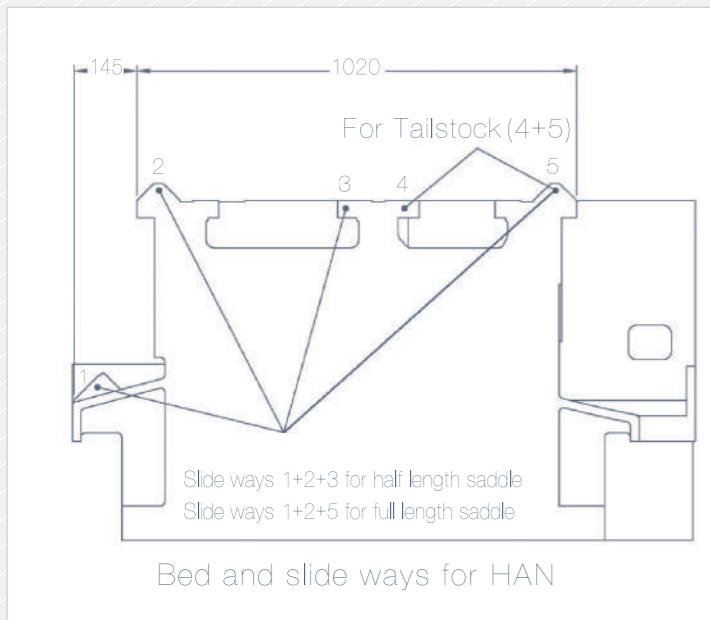

Two saddles with different device such as milling with Y axis / driving tool turret with Y axis / different turret / grinding device for machining.

We have rich customization experience and it is also our profession to make better customer also our profession to make better customer requested machine.

FULL LENGTH CROSS SLIDE



HALF LENGTH CROSS SLIDE

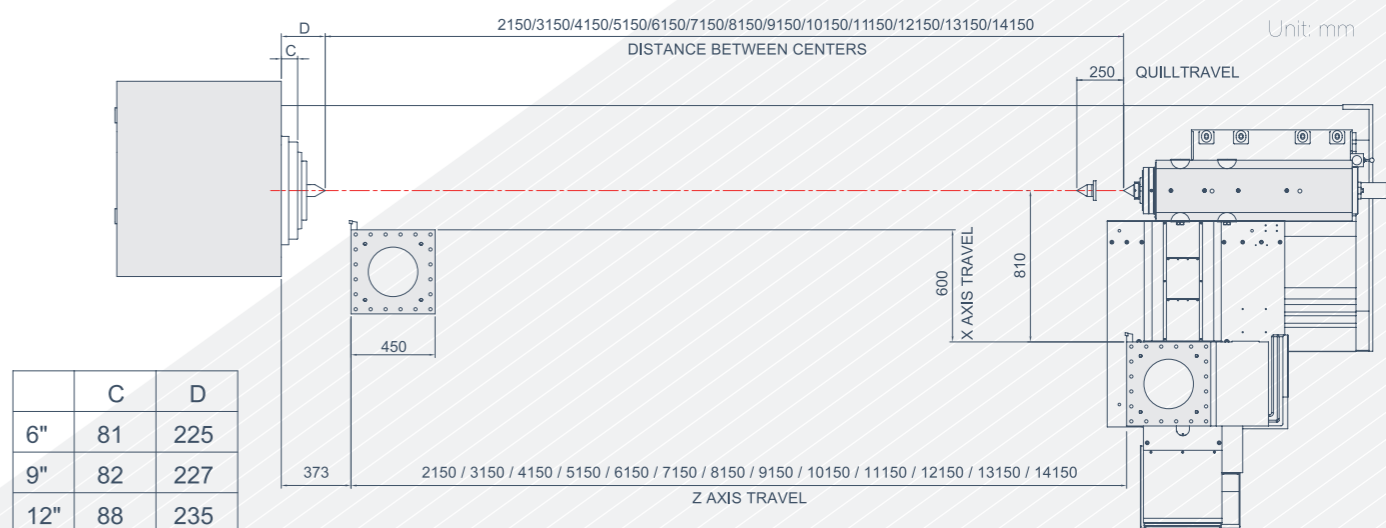

4 Bed Ways With Half Length Saddle



Rotating Quill Tailstock (STD.)

OPTIONAL

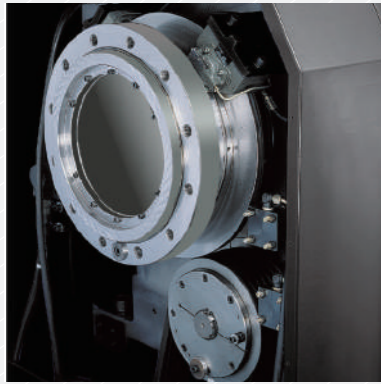

HYDRAULIC DISK BRAKE AND REAR CHUCK ADAPTOR

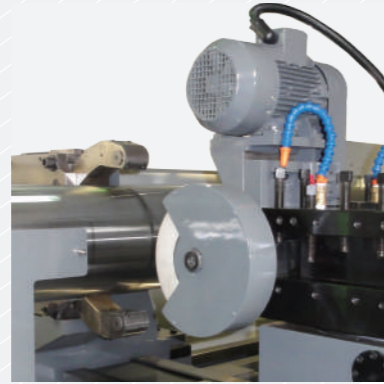

GRINDING DEVICE (TURRET TYPE)

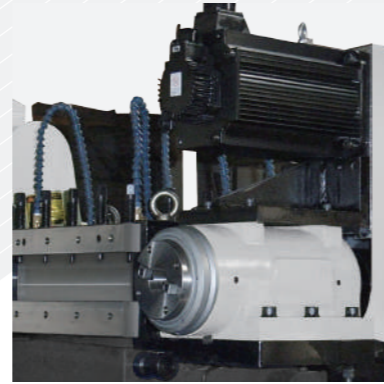

HEAVY CUTTING MILLING HEAD

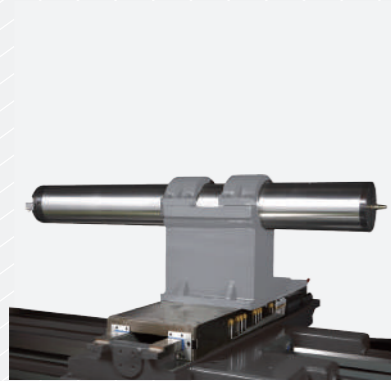

BORING BAR AND HOLDER

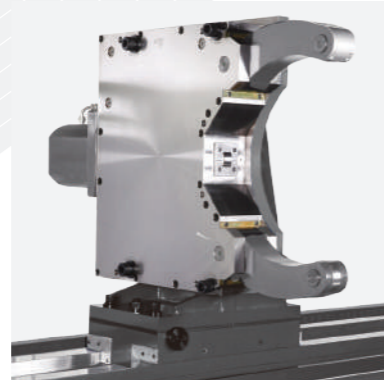

HYD. STEADY REST

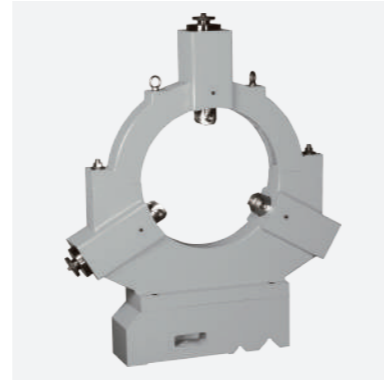

STEADY REST



HAN SPINDLE TORQUE POWER DIAGRAM

FANUC α ii30 / 6000 motor

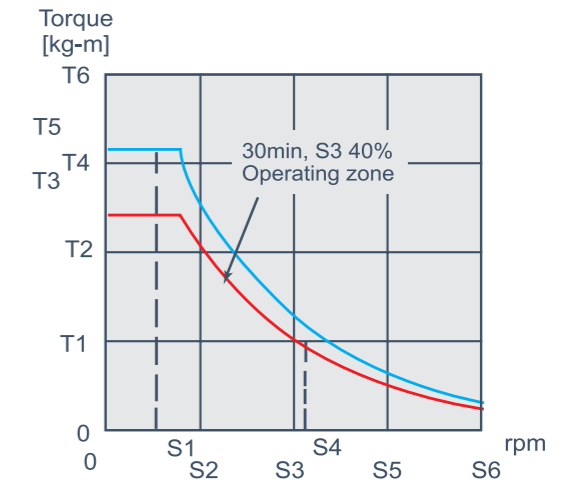
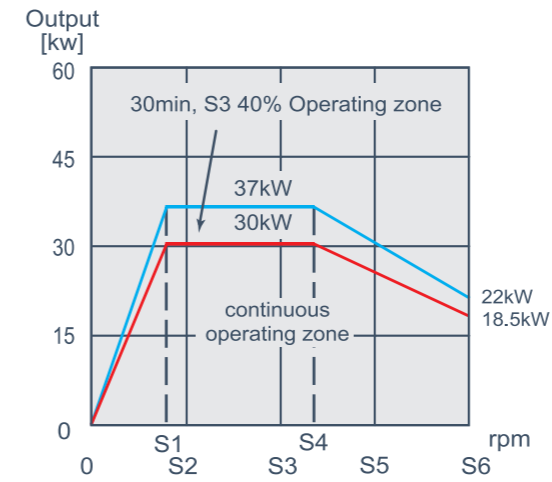

	Speed[rpm]						Torque[kg-m]					
	S1	S2	S3	S4	S5	S6	T1	T2	T3	T4	T5	T6
Motor	1150	1500	3000	3500	4500	6000	10	20	25.41	30	31.34	40
Spindle M41 i = 0.006	7	9	18	21	27	36	1667	3333	4234	4448	5222	6667
Spindle M42 i = 0.0155	18	23	47	54	70	93	645	1290	1639	1935	2021	2581
Spindle M43 i = 0.0375	43	56	113	131	169	225	267	533	677	800	835	1067
Spindle M44 i = 0.0975	112	146	293	341	439	585	103	205	260	308	321	410

HA-N DIMENSION

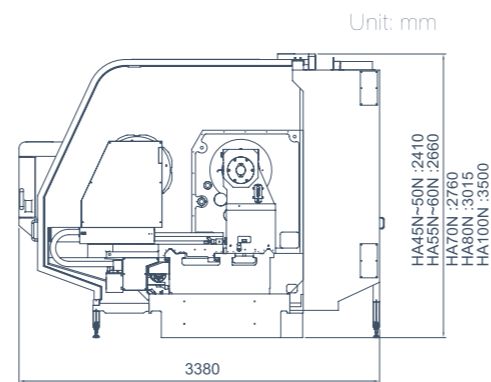
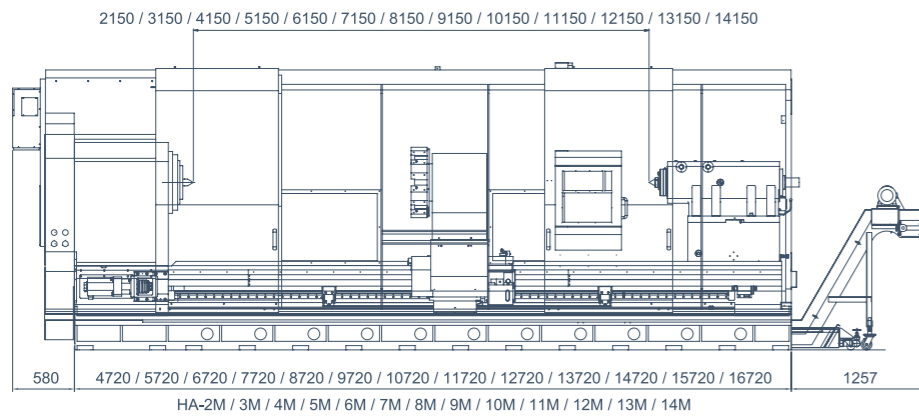

HA-H DIMENSION

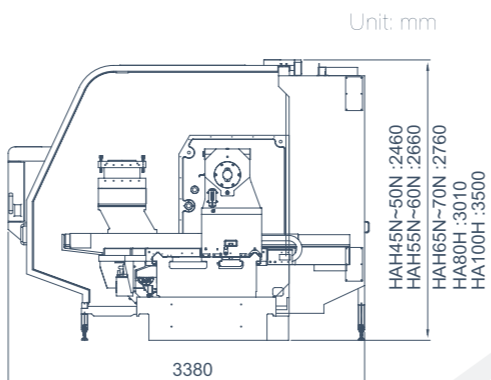
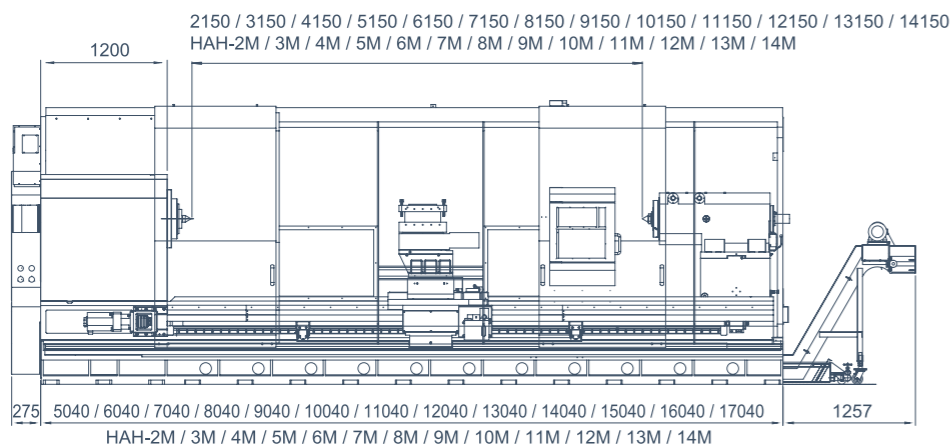

HAH SPINDLE TORQUE POWER DIAGRAM

FANUC α ii40 / 6000 motor

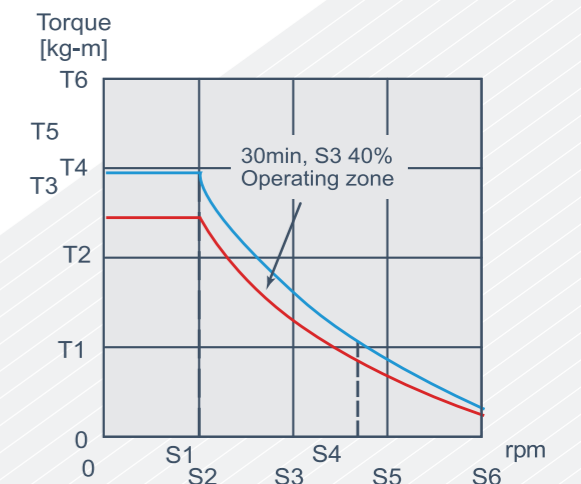
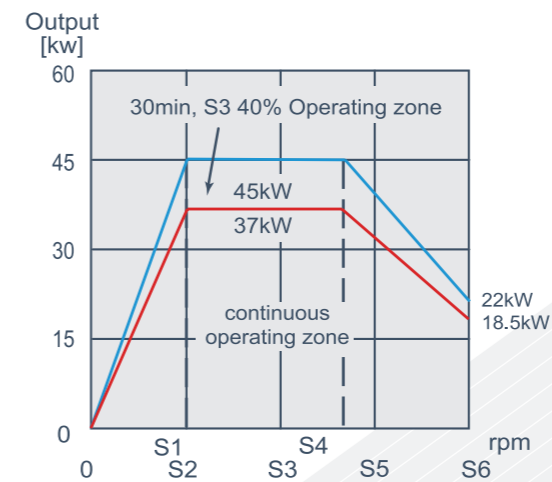

	Speed [min]					Torque [kg-m]					
	S1	S2	S3	S4	S5	T1	T2	T3	T4	T5	T6
Motor	1500	3000	4000	4500	6000	10	20	24.03	29.22	30	40
Spindle M41 i=0.00359	5	11	14	16	22	2786	5571	6692	8139	8357	11142
Spindle M42 i=0.00794	12	24	32	36	48	1259	2519	3025	3680	3778	5038
Spindle M43 i=0.0227	34	68	91	102	136	441	881	1058	1287	1322	1762
Spindle M44 i=0.05025	75	151	201	226	302	199	398	478	581	597	796

SPECIFICATIONS



MODEL	ITEM	HA45N	HA50N	HA55N	HA60N	HA70N	HA80N	HA100N	
Capacity	Swing over bed	1170 mm (46")	1300 mm (51")	1430 mm (56")	1560 mm (61")	1800 mm (70")	2050 mm (80")	2550 mm (100.3")	
	Swing over cross slide (Half length)	845 mm (33.2")	965 mm (38")	1090 mm (42.9")	1215 mm (47.8")	1465 mm (57.6")	1715 mm (67.5")	2215 mm (87.2")	
	Swing over cross slide (Full length)	720 mm (28.3")	850 mm (33.5")	950 mm (38.6")	1110 mm (43.07")	1370 mm (53.9")	1630 mm (64.1")	2150 mm (84.6")	
	Center height	585 mm (23")	650 mm (25.6")	715 mm (28.1")	780 mm (30.7")	910 mm (35.8")	1040 mm (40.9")	1250 mm (49.2")	
	Distance between centers	2150 ~ 14150 mm (84") ~ (557")							
	Bed width / Auxiliary guide	1020 mm (40") / 1170 mm (46")							
	Width of cross slide	420 mm (16.5")							
	Width of carriage	950 mm (37.4")							
Spindle	Spindle nose	A2-11 (6") / A2-15 (9") / A2-20 (12", 14") - FA45N ~ FA100N A2-28 (16") - FA55N ~ FA100N A2-28 (21") - FA60N ~ FA100N							
	Spindle speeds	A2-11 153 mm (6")	9 ~ 600 rpm (OPT: 12 ~ 800 rpm)						
		A2-15 230 mm (9")	9 ~ 450 rpm (OPT: 12 ~ 600 rpm)						
		A2-20 305 mm (12")	9 ~ 400 rpm						
		A2-20 369 mm (14.5")	9 ~ 300 rpm						
		A2-28 408 mm (16")	6 ~ 250 rpm						
	A2-28 534 mm (21")	6 ~ 220 rpm							
Spindle center	MT6								
Turret	Turret	H4-450 Servo or V8 Hydraulic							
	Tool size	32 x 32 mm (1.25")							
	X axis travel (Half length cross slide)	600 mm (23.6")							
	X axis travel (Full length cross slide)	900 mm (35.4")							
	Z axis travel	2150 mm (45.3") ~ 14150 mm (557")							
	X axis rapid travel ball screw dia.	6 m/min, dia. 40 mm x P5							
	Z axis rapid travel ball screw dia.	6 m/min, 1 ~ 5M (Dia. 63 mm x P10); 5 m/min, 6 ~ 7M (Dia. 80 mm x P10) 5 m/min, 8 ~ 14M (Rack and Pinion Driver)							
Tailstock	Tailstock quill diameter	Dia. 250 mm (9.84") OPT.: dia. 350 mm (13.7")							
	Tailstock quill travel	250 mm (9.84") / OPT.: 300 mm (11.8")							
	Tailstock center	MT6							
Motor	X axis servo motor	FANUC αiF22 4 kW							
	Z axis servo motor	2 ~ 3M FANUC αiF22 4 kW, 4 ~ 7M FANUC αiF22 4 kW (Gear Box) 8 ~ 14M FANUC αiF40 6 kW (Rack and Pinion Driver)							
	Spindle motor	FANUC αiL 30 30/37 kW (40/50 HP)							
	Lubricant pump motor	25 W							
	Coolant pump motor	1.2 kW							
	Hydraulic pump motor	2.25 kW							
	Machine weight	2000 mm center distance	17500 kgs	18000 kgs	18600 kgs	19200 kgs	20400 kgs	21600 kgs	25500 kgs
	Each extra 1000 mm weight	1500 kgs							

- All specification, design and characteristics shown on this catalogue are subject to change without prior notice.

STANDARD ACCESSORIES

- Fanuc control and motors
- 6" spindle bore
- H4 or V8 hydraulic turret
- Auto coolant, hydraulic and lubrication system
- Box way on cross slide
- Splash guard
- Hydraulic tailstock with rotating quill
- Front and rear chip conveyor
- Work light
- Tool box with tools

OPTIONAL ACCESSORIES

- Extra spindle bore, motor and speeds
- Spindle oil chiller
- Hydraulic / manual chuck
- Face plate
- C axis or spindle 5 / 15 degree indexing
- Y axis
- Driving tool turret
- Steady rest, follow rest (Hydraulic or Manual)
- Special boring bar holder
- Heavy duty milling attachment

SPECIFICATIONS

MODEL	ITEM	HA45H	HA50H	HA55H	HA60H	HA70H	HA80H	HA100H
Capacity	Swing over bed	1170 mm (46")	1300 mm (51")	1430 mm (56")	1560 mm (61")	1800 mm (70")	2050 mm (80")	2550 mm (100.3")
	Swing over cross slide (Half length)	845 mm (33.2")	965 mm (38")	1090 mm (42.9")	1215 mm (47.8")	1465 mm (57.6")	1715 mm (67.5")	2215 mm (87.2")
	Swing over cross slide (Full length)	720 mm (28.3")	850 mm (33.5")	950 mm (38.6")	1110 mm (43.7")	1370 mm (53.9")	1630 mm (64.1")	2150 mm (84.6")
	Center height	585 mm (23")	650 mm (25.6")	715 mm (28.1")	780 mm (30.7")	910 mm (35.8")	1040 mm (40.9")	1250 mm (49.2")
	Distance between centers	2150 ~ 14150 mm (84") ~ (557")						
	Bed width / Auxiliary guide	1020 mm (40") / 1170 mm (46")						
	Width of cross slide	420 mm (16.5")						
	Width of carriage	950 mm (37.4")						
Spindle	Spindle nose	A2-15						
	Spindle bore	Dia. 200 mm (8")						
	Spindle speeds	5 ~ 225 rpm						
	Spindle center	MT6						
Turret	Turret	H4-450 Servo or V8 Hydraulic						
	Tool size	32 x 32 mm (1.25")						
	X axis travel (Half length cross slide)	600 mm (23.6")						
	X axis travel (Full length cross slide)	900 mm (35.4")						
	Z axis travel	2150 mm (45.3") ~ 14150 mm (557")						
	X axis rapid travel ball screw dia.	6 m/min, dia. 40 mm x P5						
Z axis rapid travel ball screw dia.	6 m/min, 1 ~ 5M (Dia. 63 mm x P10); 5 m/min, 6 ~ 7M (Dia. 80 mm x P10) 5 m/min, 8 ~ 14M (Rack & Pinion Driver)							
Tailstock	Tailstock quill diameter	350 mm (13.7")						
	Tailstock quill travel	300 mm (11.8")						
	Tailstock center	MT6						
Motor	X axis servo motor	FANUC αiF22 4 kW						
	Z axis servo motor	2 ~ 3M FANUC αiF22 4 kW, 4 ~ 7M FANUC αiF22 4 kW (Gear box) 8 ~ 14M FANUC αiF40 6 kW (Rack and Pinion Driver)						
	Spindle motor	FANUC αiL 40 37/45 kW (50/60 HP)						
	Lubricant pump motor	25 W						
	Coolant pump motor	1.2 kW						
	Hydraulic pump motor	2.25 kW						
Machine weight	2000 mm center distance	17500 kgs	18000 kgs	18600 kgs	19200 kgs	20400 kgs	21600 kgs	25500 kgs
	Each extra 1000 mm weight	1500 kgs						

- All specification, design and characteristics shown on this catalogue are subject to change without prior notice.