

# SPECIFICATION 機械規格



DESCRIPTION 項目		Unit 單位	FGV500	FGV500S	FGV1000S
Capacity 容量能力	Max. grinding length - Longitudinal 最大研磨長度 - Y軸	mm	600	600	600
	Max. grinding width - Crosswise 最大研磨長度 - X軸	mm	500	500	1000
	Max. grinding height - Elevation 最大研磨長度 - Z軸	mm	200	200	200
	Max. table loading 容許加工負載	kg	400	400	700
Table 工作臺	Table size 工作臺尺寸	mm	600x550	600x550	1100x600
	T - slots (Wid x Dis x No.) T形槽 (尺寸 X 距離 X 數量)	mm	14x100x4	14x100x4	14x125x8
	Distance form table to ground 工作臺至地面距離	mm	750	750	750
	Rapit speed 工作臺速度	mm/min	5000	5000	10000
Motion Components 傳動元件	X , Y , Z Schneebberger	G2V2	25 Roller		35 Roller
	X , Y , Z HIWIN (OPT.)	C3	32x10		X-40P16
Uand-down movement 上下移動(Z)	Max. travel 最大移動行程	mm	200	200	200
	Feed Speed 移動速度	mm/min	2000	2000	2000
	Min. Input value unit 最小輸入單位	mm	0.001	0.001	0.001
Transverse movement 橫向移動(Y)	Max. travel 最大移動行程	mm	600	600	600
	Feed Speed 移動速度	mm/min	3000	3000	3000
	Min. Input value unit 最小輸入單位	mm	0.001	0.001	0.001
Shift back and forth 前後移動(X)	Max. travel 最大移動行程	mm	500	500	1000
	Feed Speed 移動速度	mm/min	5000	5000	10000
	Min. Input value unit 最小輸入單位	mm	0.001	0.001	0.001
Spindle 主軸	Built-in spindle 內藏式主軸	THG	120	150	150
	Spindle speed 主軸轉速	rpm	36000	24000	24000
Control system 控制系統			Mitsubishi M80		
Motors 馬達	Spindle 主軸	kw	11.5	15	15
	(X , Y , Z) Axis 軸向		Mitsubishi X-6kw,Y/Z-2.2kw		
	Dressing motor 修整器馬達		Mitsubishi 2.2kw		
	Oil lubrication system 潤滑油	w	50	50	50
	Coolant system 切削液		1HP		
Installation requirement 安裝需求	Air pressure 空壓需求	kg/cm2	4	4	4
	Spindle oil chiller tank 主軸冷卻油箱容量	L	10	10	10
	Lubricant tank 潤滑油容量	L	10	10	10
	Coolant tank 切削液容量	L	140	140	140
Machine dimensions 機械尺寸	Machine height (H) 機械高度(高)	cm	228	228	228
	Required floor space (W x L) 占地面積(寬 X 長)	cm	200x200	200x200	210x300
	Machine weight 機械重量	kg	5200	5300	6500

## High Percision CNC Gantry Grinding Machine Special for Linear Block Grinding

高精度CNC龍門磨床 線軌滑塊專用配置

※ THE SPECIFICATIONS ARE SUBJECT TO CHANG WITHOUT PRIOR NOTICE.  
本公司保留機械設計及規格變更之權利，恕不另行通知。



FORCE ONE MACHINERY CO., LTD.

No.5, Ln. 272, Dalin Rd., Daya Dist. Taichung City 428, Taiwan

Tel: +886-4-2560 2506 Fax: +886-4-2560 2460

E-mail: sales@forceonecnc.com http://www.forceonecnc.com



# Extremely stable performance

Multi-wall box-type construction on structural on structural parts, combined with 3D rib reinforcement, provides increased stability in high speed machining operations.

機械結構設計採用多重箱型結構設計,再配合最佳化3D肋骨強化,在高速加工更能表現出其卓越穩定。



Grinding wheel and table mounted roller dressers can be configured for automatic dressing and compensation. Suitable for grinding high precision linear block.

可配置砂輪和台式滾輪修整器,實現自動修整和補償。適用於磨削高精度線軌滑塊。

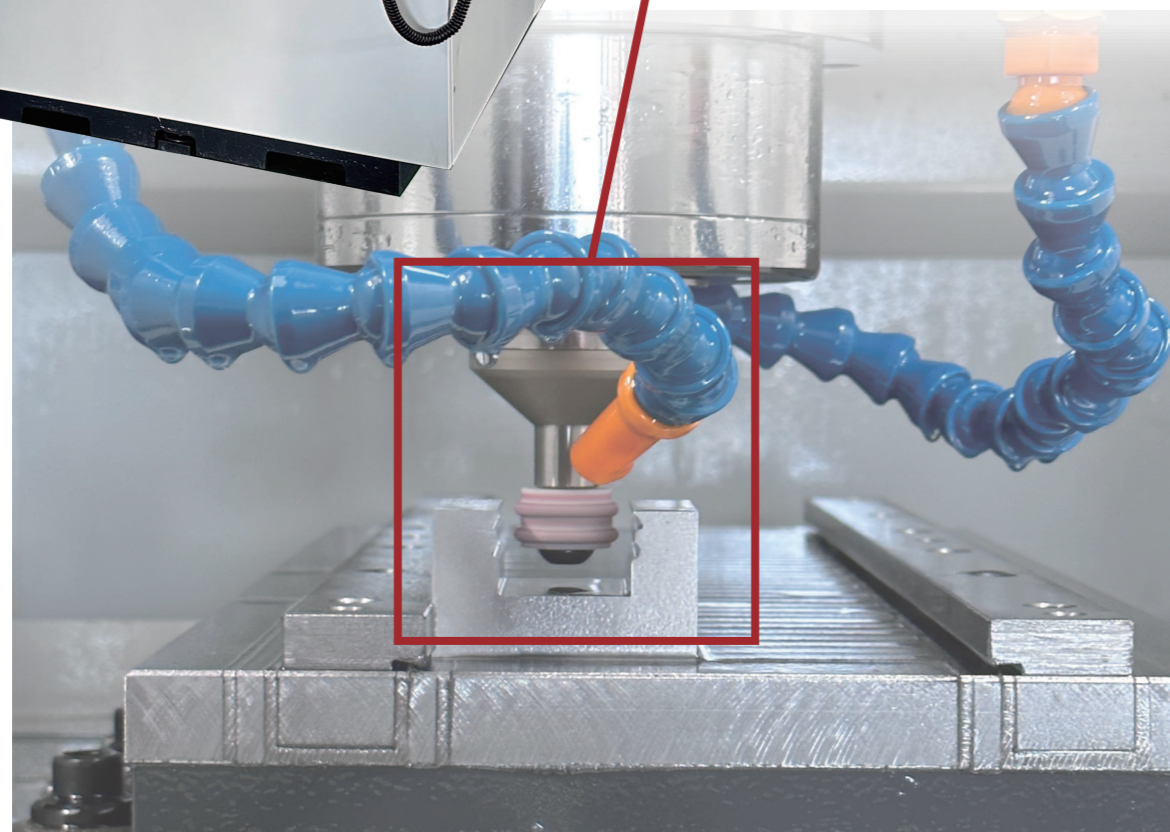

High-precision grinding configuration of linear block, combined with magnetic texture, is convenient, efficient and stable.

高精度線軌滑塊研磨配置,搭配磁性固定治具,高速、穩定多軸,橋式結構,高精度。

# Highly rigid gantry structure design, excellent precision performance

高剛性門架式結構設計,絕佳精度表現

QUALITY EFFICIENCY PERFORMANCE

The gantry type structure is one-piece constructed to assure the best possible rigidity and stability of structure. Structural parts are manufactured from high quality Mechanists cast iron, tempered and stress relieved for excellent cutting stability and lifetime accuracy. The X, Y, Z axes linear slide rails make the heavy cutting process faster and more stable, ensuring optimum grinding accuracy. This machine is designed for slow feed grinding and can be widely used in many fields, including, the aerospace, automotive, medical and mold industries.

門式結構採用一體成型,以確保最佳的剛性和結構穩定性。結構部件由高品質的鑄鐵製造,經過回火和消除應力處理,以提供卓越的切割穩定性和長期精度。X、Y、Z軸的線性滑軌使重切削過程更快更穩定,並確保最佳的研磨精度。此機台的設計用於慢速進給研磨,可廣泛應用於航空、汽車、醫療和模具行業。

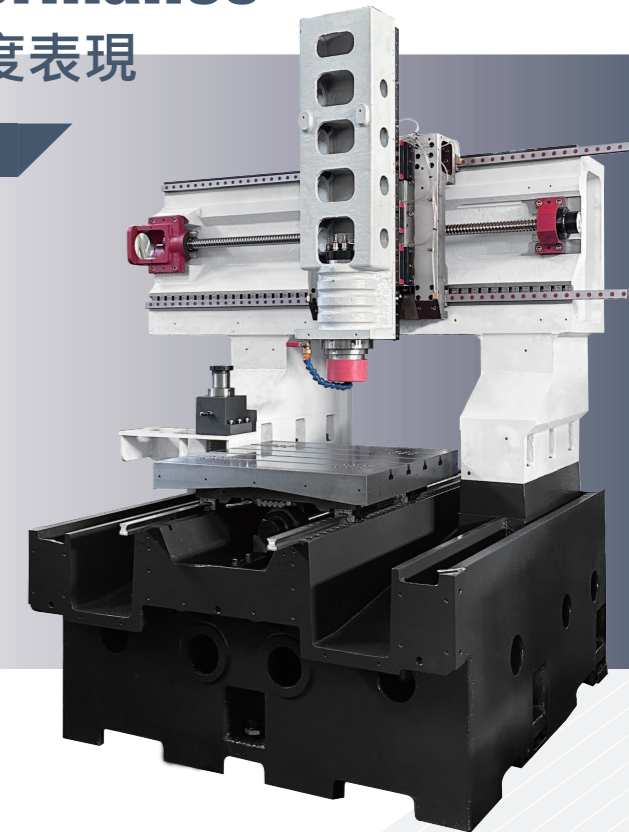

Built-in Spindle 內藏式主軸



Human - Computer Interface 智慧人機介面

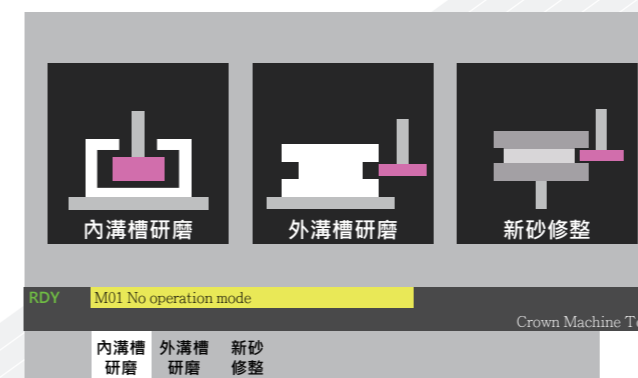

Screw With Hollow Cooling System 中空螺桿冷卻系統

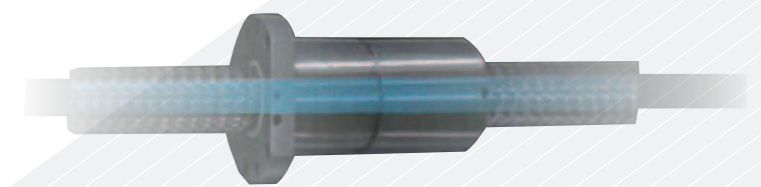

Standard Equipment 標準配備

- |                            |          |
|----------------------------|----------|
| Built - in Spindle         | 內藏式主軸    |
| Spindle Cooling Device     | 主軸冷卻裝置   |
| Auto. Lubrication          | 三軸自動潤滑系統 |
| Oli mist Collecting Device | 油霧回收裝置   |
| Transformer                | 變壓器      |
| Magnetic Separator         | 高氧磁鐵過濾機  |
| Paper Filter               | 紙帶過濾器    |
| Work Lamp                  | 工作燈      |
| Tools & tools box          | 調整工具及工具箱 |
| 1 Year Machine Warranty    | 機器保固 1年  |
| 2 Year Control Warranty    | 控制器保固 2年 |